

Mechanical spectroscopy of thin polystyrene films

Tatjana Haramina^{a,*}, Reiner Kirchheim^a, Arti Tibrewala^b, Erwin Peiner^b

^aInstitut für Materialphysik, Georg-August-Universität Göttingen, D-37077 Göttingen, Germany

^bInstitut für Halbleitertechnik, Technische Universität Carolo-Wilhelmina zu Braunschweig, D-38106, Germany

ARTICLE INFO

Article history:

Received 24 October 2007

Received in revised form 28 February 2008

Accepted 1 March 2008

Available online 5 March 2008

Keywords:

Mechanical spectroscopy

Thin film

Glass transition

ABSTRACT

Mechanical spectroscopy is applied to thin polystyrene films of 7.5–730 nm thickness spin coated on a thin silicon reed. Below a thickness of 100 nm, the α -relaxation peak (glass transition) broadens considerably and shifts to lower temperatures by a few degrees. These effects are attributed to a different polymer dynamics at the polymer/vacuum and the polymer/silicon interfaces.

© 2008 Elsevier Ltd. All rights reserved.

1. Introduction

The study and application of very small systems are driven by nanotechnology and by basic materials science, because it is still not completely understood how the properties of materials will change by reducing the dimensions of the systems. In particular, studies of the glass transition and dynamics in thin polymer films offer great promise to increase our understanding of dynamics in polymeric systems and in glass forming systems in general. Below a certain thickness, which is dependent on the molecular weight, M_w , and the radius of gyration, R_g , the confinement between two interfaces (in this study a solid substrate and a free surface) restricts the free arrangement of polymer chains and deviations from unperturbed coil conformation are expected. Decreasing the film thickness down to the order of the unperturbed chain dimension increases the in-plane length of the chains [1,2].

In recent years the finite size effects on glass transition were investigated intensively, but often with conflicting results, mainly because measurements were not performed in the same way. The observed depression of the glass transition temperature as a consequence of reduced dimensions was attributed to: (i) the presence of a free surface [3], (ii) the effect of molecular weight [4] and (iii) the heating or cooling rate [5]. In order to observe an increase in the amount of free volume by reducing the thickness of a film, one has to have at least one free surface. Theoretical considerations [6] and experiments [7] on polystyrene showed that the preferred orientation of aromatic rings are out of the interface plane, at both

interfaces, though the tilt angle with respect to the surface normal is higher at the film/substrate interface than at the free surface. The preferential orientation at the solid/film interface leads to a higher density and a lower amount of the free volume. At the free surface, however, though the molecules are preferentially oriented, the amount of free volume increases. In Ref. [4] it was reported that the higher the M_w , the higher will be the critical thickness below which T_g decreases with film thickness. Ellipsometric measurements [23] showed that the higher the cooling rate the smaller will be the effect, with the critical cooling rate of 90 K/min where no effect at all was observed. As an explanation for the effect it was suggested that the cooling rates can be considered as an inverse of some relaxation time probed by the experiment, hence by a fast cooling rate, slow dynamics cannot be observed. Therefore, in this study a low heating/cooling rate, a rather high M_w and one free surface were chosen.

In most studies a thermodynamic property such as volume or heat capacity was measured as a function of temperature showing a break or jump at the glass transition temperature. However, ellipsometric measurements of Fakhraai et al. [5] on thin PS bilayers revealed that the out of plane relaxation becomes slower by reducing the film thickness, although a decrease of T_g with reducing film thickness was observed. This led to the conclusion that measurements of T_g alone cannot be used to predict chain dynamics and vice versa [5,22], and, therefore, dynamical measurements showing the whole relaxation process are very useful in this context. Only a few dynamical studies applying dielectric loss spectroscopy have been published so far. The method allows investigation of the same sample at different frequencies and, therefore, the frequency dependent glass transition can be accessed. However, the measured film is usually confined between two electrodes, without

* Corresponding author. Tel.: +385 1 6168 249.

E-mail addresses: tharamina@fsb.hr, haramina@ump.gwdg.de (T. Haramina).

a free surface left. An exception was reported in Ref. [8], where small spheres were used to separate electrode and polymer surface and thus a free surface between the spheres had been realized. An alternative to dielectric spectroscopy is mechanical spectroscopy of supported thin polymer films. By the latter method the effect of reduced dimensions on dynamics of polymer films near the glass transition with one free surface can be studied, though the changes of the frequency are limited. The technique has been used by Nagy et al. [9] to study the conversion of poly(phenylene-vinylene) to a conjugated polymer and the technique is applied in this study for supported thin polystyrene films. The mechanical loss of a material also termed internal friction is caused by conformational changes leading to a phase shift between stress and strain during periodic excitations and a damping of a freely vibrating sample. The higher the phase shift, the higher will be the damping of the material. Damping is maximal when the period of molecular motions becomes comparable to the time scale of the experiment. Thus different relaxation processes lead to peaks in mechanical spectra. In this study the α -relaxation which is attributed to the glass transition is observed at frequencies of 100 and 200 Hz. In order to perform the experiments a vibrating reed apparatus was developed. This technique is well established for non-destructive characterization of metal layers [10].

2. Experimental

The polystyrene analyzed in this study has a high molecular weight of 1070 kDa and the polydispersity index of 1.06. A polymer solution of 0.017% in toluene was prepared and spin coated on a Si(100) reed and different film thicknesses were achieved by spin coating one layer on top of the previous one. Such a layered structure of PS prepared by spin coating and annealing each layer above the bulk T_g does not influence the ellipsometric T_g [18,19]. Additionally, any influence of different solution concentration or spin speed is excluded. In the case of mechanical loss measurement keeping the eigenfrequency at a certain temperature nearly constant is very important and this was achieved by having the geometry of the substrate unchanged. The silicon reed was prepared by etching of a silicon wafer leading to a form as shown in Fig. 1. The Si-frame containing the vibrating reed plus PS film was mounted in a vacuum chamber between two copper plates and then annealed at a temperature slightly above T_g (i.e. 380 K). In order to avoid diffusion of Cu into Si an aluminium foil is placed between the two materials. Samples were placed in the vibrating reed apparatus immediately after spin coating and the chamber was evacuated afterwards in order to avoid oxidation or moisture uptake. In Ref. [15] an effect on T_g down to 20 nm was observed only for films

annealed in the air. In our experiment sample annealing above T_g was done within the apparatus in vacuum and in the dark, hence the solvent evaporates faster and the relaxation of residual stresses in the film took place in the absence of moisture or UV light.

Residual stresses provide an extra driving force for dewetting and by aging or when heating above the T_g the chains will adopt conformations closer to their equilibrium [21]. The width of the rims formed by the relaxation as a result of collecting the dewetted liquid is smaller for films being annealed for longer periods at 50 °C than at the ambient temperature. A detailed study of the relaxation of stresses generated by spin coating was done by Damman et al. in Ref. [20]. The annealing times in our experiments were long enough to relax the major fraction of the residual stresses. Heating of samples from the ambient temperature to $T > T_g$ in the vacuum chamber lasted several hours and after annealing the chamber was cooled down again for several hours. Repeated cycles with the heating rate 0.2 K/min significantly extended the aging and the annealing time and did not affect the relaxation spectra. Therefore it is assumed that after annealing the spin-coated films had conformations similar to those of equilibrated melts [20].

The reed can be excited capacitively to a simple bending mode, because the silicon is p-doped with sufficient electrical conductivity. The free decay of the corresponding amplitude was measured by the deflection of a laser beam and a position sensitive detector (PSD). Temperatures were obtained from a Pt1000 resistance mounted between the copper clamps. The temperature rise or drop was 0.2 K/min and it was considered to be constant during one measurement of the loss modulus which lasts 0.4 min.

The storage modulus of the composite PS film and silicon substrate is almost equal to that of silicon and, therefore, the frequency of the reed is changed slightly by the PS film only (see Eq. (1)). However, the loss modulus of PS is many orders of magnitude larger than the one of Si. Thus even thin PS films affect the damping of the composite (see Eq. (2)). For a quantitative analysis see Ref. [9–11]. In order to measure very thin PS films, the form and dimensions of the substrate are chosen such that the mechanical damping of the vibrating reed is as small as possible. The sample shape includes a step between the vibrating reed and the frame, similar to those reeds used by Mizubayashi et al. [10]. Thus friction in the clamps which causes high energy losses is avoided. The damping of the silicon reeds is then mostly determined by thermoelastic damping, which is proportional to the third power of the reed thickness and inversely proportional to the square of the reed length [12]. Thus reeds having small thicknesses of 30–60 μm only were used.

3. Results

The film thickness is calculated from the difference of the eigenfrequencies, Δf , of the pure Si substrate and of the composite sample consisting of the substrate and a polymer film as [10,11]:

$$\frac{\Delta f}{\Delta f_s} = \left(\frac{3E_f}{2E_s} + \frac{\rho_f}{2\rho_s} \right) \frac{d_f}{d_s} \quad (1)$$

where E is the elastic modulus, ρ is the density and d is the thickness. The suffixes s and f refer to the substrate and the film, respectively. As already mentioned, the density of the film at both interfaces is higher due to the preferential orientation of phenyl rings. In Refs. [16,17] a decrease in film thickness of films being annealed and aged was reported. Richardson [16] measured a decrease in film thickness h compared to h_∞ for films prepared from a melt by annealing spin-coated PMMA films below T_g . The decrease is probably due to the structural relaxations combined with solvent loss. The thicker the film is, the higher will be the effect. For films below 100 nm the effect is rather small and the film

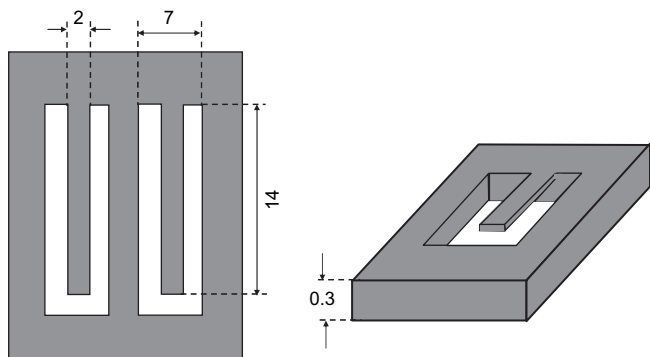

Fig. 1. A top view of the wet etched cantilevers (left). The vibrating reeds in this figure are surrounded by white colour. After etching the piece is broken along the symmetry axis and one of the parts is presented on the right hand side in 3D projection. The numbers presented in the figure are in mm.

density before annealing is close to h_{∞} . In the mechanical spectroscopy experiments, a weight loss due to the solvent evaporation below or above the T_g would affect the eigenfrequency of the sample and this was not observed. Thus, in Eq. (1), an assumption that the average film density is close to the density of bulk PS, ρ_{∞} , is made. Film thicknesses were also determined experimentally in a secondary electron microscope. The composite substrate plus film were either broken after cooling down to liquid nitrogen temperature or a cross-section was prepared by producing a crater with a focused ion beam. A comparison of calculated and measured film thicknesses is shown in Fig. 2.

Measured mechanical spectra for films thicker than 127 nm on a Si-reed with an eigenfrequency of about 200 Hz are presented in Fig. 3 as the difference of the reciprocal quality factors of the film/substrate composite and the substrate, i.e. $\Delta Q^{-1} = Q_c - Q_s$. The substrate value Q_s increased slightly with temperature from 1×10^{-6} at 300 K to 3×10^{-6} at 480 K. The spectra in Fig. 3 show that the peak position and the width of the α -relaxation are independent of film thickness.

The internal friction of the composite is obtained as [11]:

$$Q_c^{-1} = \frac{Q_s^{-1} + Q_f^{-1} W_f / W_s}{1 + W_f / W_s}, \quad (2)$$

where W is the stored elastic energy during one cycle of the vibrating reed for the PS film (subscript f) or the substrate (subscript s). As both modulus and thickness are much smaller for PS than for silicon, Eq. (2) can be simplified to:

$$\Delta Q^{-1} = Q_c^{-1} - Q_s^{-1} = \frac{W_f}{W_s} Q_f^{-1} = \frac{3E_f d_f}{E_s d_s} Q_f^{-1} \quad (3)$$

Only the relaxation strength, which is related to the amount of the material participating in the relaxation process increases.

Thinner films were deposited on a Si-reed with an eigenfrequency of about 100 Hz but similar Q_s values as given before. ΔQ^{-1} data of these films are presented in Figs. 4 and 5. In these cases a clear broadening of the relaxation peak and its shift to lower temperatures with reducing thicknesses is observed. For the sake of an easy comparison the mechanical spectra of thin films are fitted to Gauss functions and normalized to the same heights (cf. Fig. 5). The spectra shown in Figs. 3 and 4 are not directly comparable, because measurements are performed at different frequencies because of slightly different thicknesses of the silicon substrates (the higher the frequency, the higher is the peak temperature).

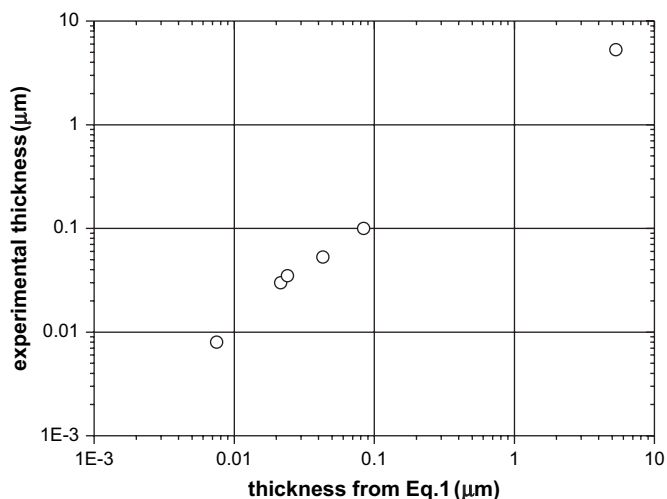

Fig. 2. Thickness of the PS films determined experimentally by SEM from cross-sections of the film/substrate composite and from frequency shifts via Eq. (1).

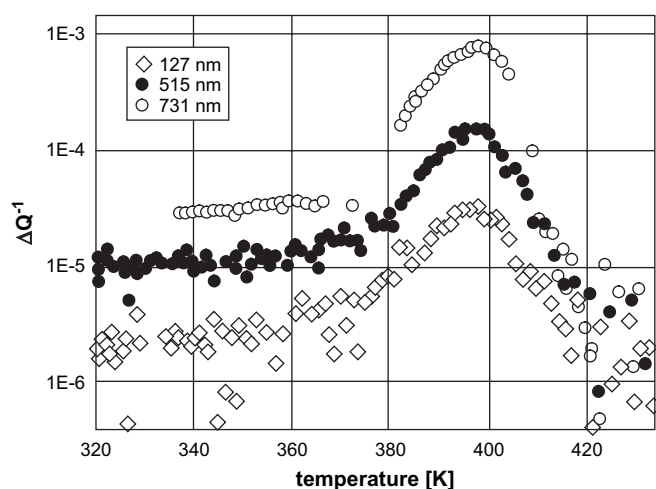

Fig. 3. Mechanical loss spectra containing the α -relaxation, i.e. the glass transition of thick films. The eigenfrequency of the sample is 200 Hz.

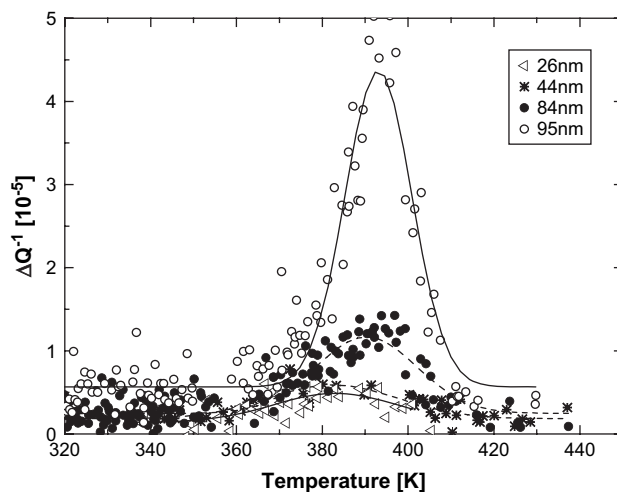

Fig. 4. Mechanical loss spectra of thin films after subtracting the silicon contribution. The eigenfrequency of the sample is 100 Hz.

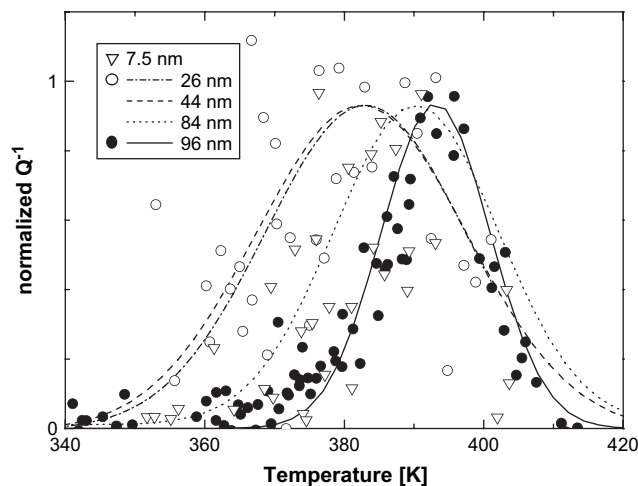

Fig. 5. Data from Fig. 4 but normalized to the same heights and fitted to Gaussian functions. The eigenfrequency of the sample is 100 Hz. The triangles not shown in Fig. 4 correspond to a 7.5 nm thick PS film.

4. Discussion

The increased width of the peak for the thinnest films is attributed to an increasing width of the distribution of relaxation times. The corresponding contributions occur mostly on the low temperature side of the peak, i.e. are due to processes of lower activation energy. Thus they affect the onset of the α -relaxation mostly and less the maximum peak temperature (cf. Fig. 5). The onset temperature is defined as the temperature where the base line and the tangent in the first inflection point of the α -peak intercept. The corresponding temperatures are defined as glass transition temperatures and their dependence on film thickness is plotted in Fig. 6. Thus T_g decreases slightly by about 10 K for the film thickness decreasing from about 100 to 7.5 nm. This small effect is not due to a fast heating rate because in this study a rate of 0.2 K/min had been used which is much smaller than the critical value published in Ref. [23].

As the thickness of the PS film decreases the scatter of the ΔQ^{-1} values increases considerably as they are obtained by subtracting the two larger quantities Q_c^{-1} and Q_s^{-1} . Nevertheless, a relaxation peak has been observed for a 7.5 nm thick film (cf. Fig. 5). However, the errors in determining peak position and peak width are considerably ± 5 K and ± 2 K, respectively.

In the following the results of this study are interpreted by a simple model, where the film of total thickness d consists of three layers: (i) one at the surface with thickness d_1 having a higher free volume content as discussed before and a lower glass transition temperature than bulk, (ii) a more dense layer at the film/substrate interface with thickness d_s and a higher T_g compared to bulk, and (iii) a layer in-between behaving like bulk. For a film thickness d being much larger than $d_1 + d_s$ the α -peak is the same as for bulk PS. For d approaching the value $d_1 + d_s$ both interface layers contribute increasingly to the measured relaxation peak at both higher and lower temperatures of the bulk α -relaxation. This way the observed broadening of the relaxation is explained. For $d \leq d_1 + d_s$ the measured relaxation is a superposition of the two interface layers and does not change with decreasing d . Thus the simple model explains the nearly constant onset and peak temperature for films with thicknesses below 50 nm. In order to be consistent within the framework of the model, the effect of the layer at the substrate interface on the α -relaxation should be smaller to account for the larger decrease of the onset temperature in comparison with the maximum peak temperature. This can be achieved by either a smaller thickness, i.e. $d_s < d_1$, or a smaller change of T_g .

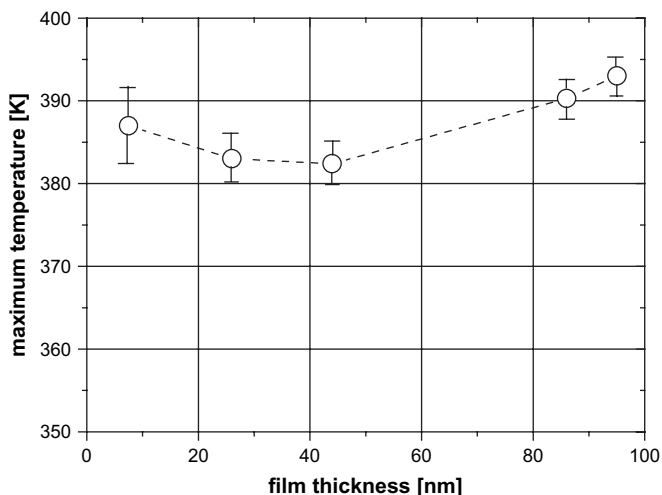

Fig. 6. Peak temperatures T_{max} as a function of film thickness. T_{max} and its error bars are obtained from a least square fit of Gaussian functions to the data between 340 and 420 K. The dashed line is drawn to guide the eyes.

The surface layer resembles the liquid-like layer introduced in Ref. [3] and having a thickness of 5 ± 1 nm. However, it should not behave as a real liquid during mechanical spectroscopy, because this would not contribute to the α -relaxation but raise the background only.

If the glass transition temperature is defined as the onset temperature, T_g decreases by about 30 K from bulk-like films with 100 nm thickness to a film with 26 nm thickness. For the maximum peak intensity being defined as T_g the decrease corresponds to about 10 K. These changes are slightly smaller than the ones observed by other techniques [3]. On the other hand much smaller or even no changes were observed by dielectric spectroscopy for PMMA with one free surface [13].

5. Conclusions

The present work demonstrates that mechanical spectroscopy is an appropriate technique to study the glass transition and/or other structural relaxations in thin polymer films supported by a substrate. Compared to competing techniques major advantages of the method are (i) a direct determination of film thickness from frequency changes, (ii) getting information about the dynamics of the relaxation and (iii) its exceptional sensitivity. The latter advantage has not been exploited thoroughly in this study yet, as it was the first attempt to apply this to films with decreasing thickness. Nevertheless, it became obvious that further improvements are possible by decreasing the background damping of the substrate, i.e. the thermoelastic contribution by reducing the reed thickness below 30 μm . In recent publication [14] silicon substrates with a thickness of 0.9 μm have been used for measuring strains in thin polymer films. In addition, the length and the widths of the reed can be changed yielding various frequencies of the simple bending mode and, therefore, allowing measurements of activation energies.

Acknowledgement

The authors are grateful for financial support provided by the Deutsche Forschungsgemeinschaft (SFB 602).

References

- [1] Kraus J, Müller-Buschbaum P, Kuhlmann T, Schubert D, Stamm T. *Europhys Lett* 2000;49:210–6.
- [2] Russel TP, Jones RL, Kumar SK, Ho DL, Briber RB. *Nature* 1999;400:146–9.
- [3] Sharp JS, Teichroeb JH, Forrest JA. *Eur Phys J E* 2004;15:473–87.
- [4] Dalnoki-Veress K, Forrest JA, Murray C, Gigault C, Dutcher JR. *Phys Rev E* 2001;63:031801.
- [5] Fakhraai Z, Valadkhan S, Forrest J. *Eur Phys J E* 2005;18:143–8.
- [6] Mason DR, Sutton AP. *Phylos Trans R Soc A* 2005;363:1961–74.
- [7] Gautam KS, Schwab AD, Dhinojwala A, Zhang D, Dougal SM, Yeganeh MS. *Phys Rev Lett* 2000;85:3854–7.
- [8] Serghei A, Kremer F. *Rev Sci Instrum* 2006;77(11):116108.
- [9] Nagy A, Strahl A, Neuhäuser H, Schrader S, Behrens I, Peiner E, et al. *Mater Sci Eng A* 2004;370:311–5.
- [10] Mizubayashi H, Yoshihara Y, Okuda S. *Phys Status Solidi A* 1992;129:475–81.
- [11] Kinsler LE, Frey AR. *Fundamentals of acoustics*. 2nd ed. New York: Wiley and Sons, Inc.; 1962.
- [12] Nowick AS, Berry BS. *Anelastic relaxation in crystalline solids*. New York: Academic Press; 1972. p. 14.
- [13] Kremer F, Serghei A, private communication.
- [14] Zhao J, Berger R, Gutmann JS. *Appl Phys Lett* 2006;89:033110.
- [15] Serghei A, Kremer F. *Prog Colloid Polym Sci* 2006;132:33–40.
- [16] Richardson H, López-García Í, Sferrazza M, Keddie JL. *Phys Rev E* 2004;70:051805.
- [17] Fukao K, Koizumi H. *Eur Phys J* 2007;141:199.
- [18] Fakhraai Z, Sharp JS, Forrest JA. *J Polym Sci Part B Polym Phys* 2004;42:4503.
- [19] Forrest JA, Sharp JS. *Phys Rev Lett* 2003;91:235701.
- [20] Damman P, Gabriele S, Coppée S, Desprez S, Villers D, Vilmin T, et al. *Phys Rev Lett* 2007;99:036101.
- [21] Reiter G, Hamieh M, Damman P, Sclavons S, Gabriele S, Vilmin T, et al. *Nature Mater* 2005;4:754.
- [22] Lupășcu V, Huth H, Schick C, Wübberhorst M. *Thermochim Acta* 2005;432:222.
- [23] Fakhraai Z, Forrest JA. *Phys Rev Lett* 2005;95:025701.